

Specification Approval Sheet

Product Description: 5.46" 2160X3840 (with pixel rendering) LCD Part			
----- Specification version v0.0			
AU Model Name: H546UAN01.0			
Customer :	Customer Model Name:		
Customer Signature	Date	AUO	2015/12/30
		Approved By: Ginie Chou	
		Prepared By: Claire Lee	

Doc. version	0.0
Effective date	Dec 30 th , 2015
Total pages	26
(Exclude this cover page)	

Product Specification

5.46" LCD

MODEL NAME: H546UAN01.0

(◆) Preliminary Specification

<p><i>AUO:</i> _____</p> <p><i>Customer:</i> _____</p>
--

Note:
The content of this specification is
subject to change.

© 2015 AU Optronics
All Rights Reserved
Do Not Copy.

Record of Revision

Ver.	Revise Date	Page	Content
0.0	2015/12/30		First draft.

Contents:

A. General specifications

B. Electrical specifications

C. Optical specifications

D. Mechanical drawing

A. General Specification

Physical specification

Parameter	Value
LCD	
Graphic format	2160 x2(RG/BR/GB)x3840 pixels (UHD)
Technology	LTPS TFT
Display thickness	1.276mm
Active area	68.04 mm x 120.96 mm
Viewing area	68.50 mm x 121.42 mm
Diagonal size LCD	5.46 inch
Pixel pitch	31.5 μ m
Illumination mode	Transmissive, Normally black
Illumination type	RG phosphor LED Backlight
Color depth	24bit (16M colors)
Display Driver	Novatek, NT35950

Abbreviations

Abbreviation	Explanation
TFT	Thin Film Transistor
LCM	Liquid Crystal Module
LCD	Liquid Crystal Display
ESD	Electrostatic Discharge
GND	Ground
RGB	Red Green Blue
CPU	Central Processor Unit
CR	Contrast Ratio
COF	Chip On Foil
COG	Chip On Glass
FPC	Flexible Printed Circuit, also known as flex
I/F	Interface
IC	Integrated Circuit
ITO	Indium-Tin-Oxide
LED	Light Emitting Diode
ZIF	Zero Insert Force
BtB	Board to Board

System configuration:

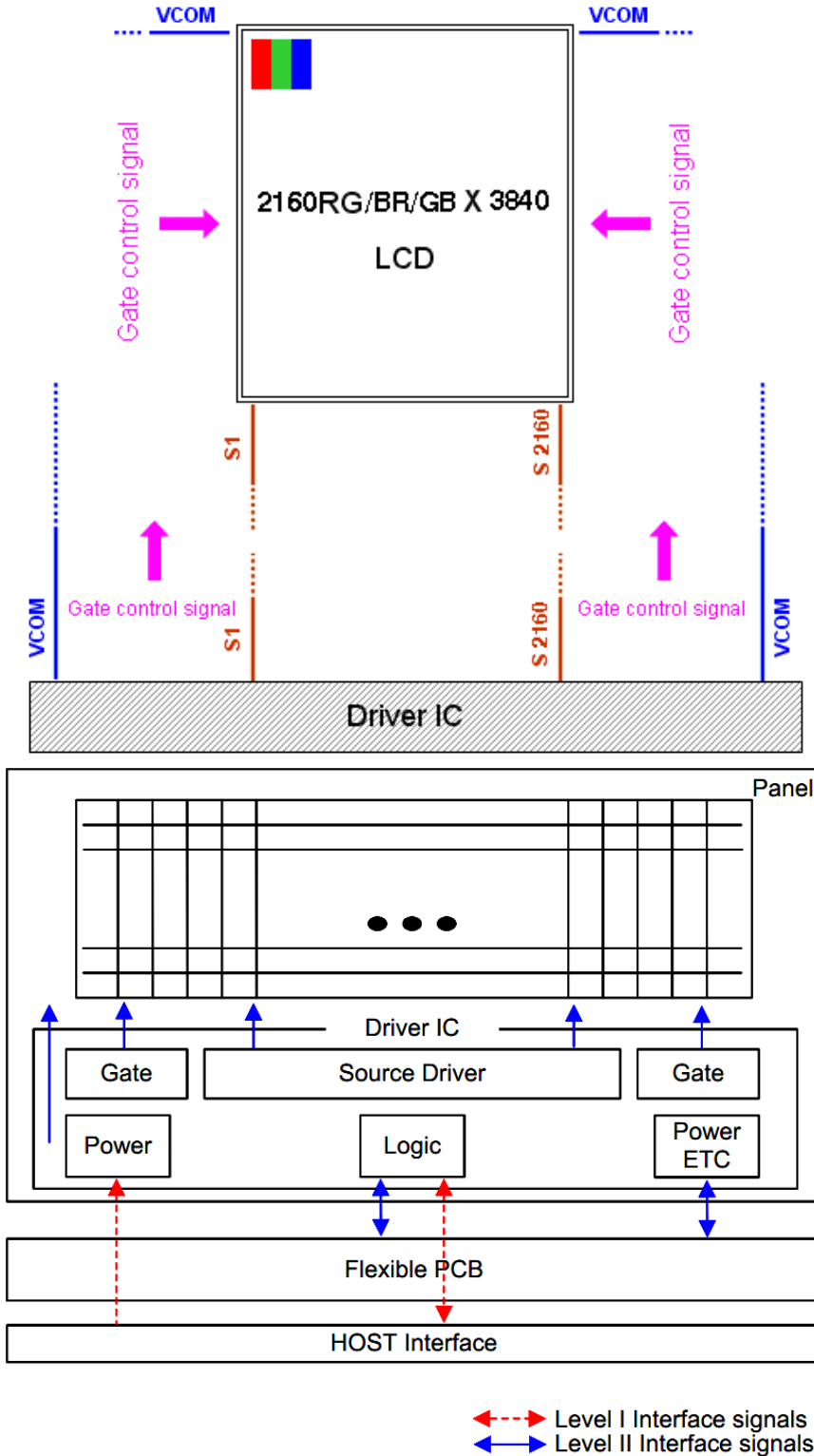

B. Electrical Specification:

Pin assignment

The interface of the LCD assembly consists of 60 interconnections. 46 connections are used for the LCD. 10 connections are used for touch panel, 4 connections are used for the LEDs.

LCD Connector

FPC	Pin_Name	I/O	Description
A30	LED_AN	I	LED Anode
A29	LED_CA3	O	LED Cathode
A28	GND	I	Ground
A27	BL_THERM	O	for Thermistor
A26	GND	I	Ground
A25	MIPI_DB0_N	I	MIPI Data
A24	MIPI_DB0_P	I	MIPI Data
A23	GND	I	Ground
A22	MIPI_DB1_N	I	MIPI Data
A21	MIPI_DB1_P	I	MIPI Data
A20	GND	I	Ground
A19	MIPI_DA3_N	I	MIPI Data
A18	MIPI_DA3_P	I	MIPI Data
A17	GND	I	Ground
A16	MIPI_CLKA_N	I	MIPI Clock
A15	MIPI_CLKA_P	I	MIPI Clock
A14	GND	I	Ground
A13	MIPI_DA2_N	I	MIPI Data
A12	MIPI_DA2_P	I	MIPI Data
A11	GND	I	Ground
A10	VDDI	I	Power supply for interface system except MIPI interface pin.
A9	VDDI	I	Power supply for interface system except MIPI interface pin.
A8	VSP	I	Positive power supply for driver IC used.
A7	VSN	I	Negative power supply for driver IC used.
A6	GND	I	Ground
A5	GND	I	Ground
A4	SDA	I/O	for TP Pin
A3	SCL	I	for TP Pin
A2	ATTN	O	for TP Pin
A1	GND	I	Ground

B30	LED_CA2	O	LED Cathode
B29	LED_CA1	O	LED Cathode
B28	GND	I	Ground
B27	MIPI_DB3_N	I	MIPI Data
B26	MIPI_DB3_P	I	MIPI Data
B25	GND	I	Ground
B24	MIPI_CLKB_N	I	MIPI Clock
B23	MIPI_CLKB_P	I	MIPI Clock
B22	GND	I	Ground
B21	MIPI_DB2_N	I	MIPI Data
B20	MIPI_DB2_P	I	MIPI Data
B19	GND	I	Ground
B18	MIPI_DA0_N	I/O	MIPI Data
B17	MIPI_DA0_P	I/O	MIPI Data
B16	GND	I	Ground
B15	MIPI_DA1_N	I	MIPI Data
B14	MIPI_DA1_P	I	MIPI Data
B13	GND	I	Ground
B12	TEST	I	For Bist mode use
B11	VSYNC	O	TE or VSYNC
B10	LCD_ID	O	LCM supplier ID
B9	LCD_RESET	I	IC Reset
B8	DVDD	I	Power supply for internal digital system.
B7	GND	I	Ground
B6	OTP_8V	I	OTP voltage
B5	GND	I	Ground
B4	GND	I	Ground
B3	VDDH	I	for TP Pin
B2	VDDL	I	for TP Pin
B1	GND	I	Ground

Assembled on	Item	Description
LCD FPC	Connector type	B to B
	Pin amount	60
	Type of connector on Module FPC	Plug
	Manufacturer	DDK
	Part number	BB35-PC60-3A-D8

Assembled on	Item	Description
LED FPC	Connector type	ZIF
	Pin amount	4
	Type of connector on Module FPC	ZIF
	Manufacturer	FCI
	Part number	10062827-0410EDHLF

Assembled on	Item	Description
TP FPC	Connector type	B to B
	Pin amount	10
	Type of connector on Module FPC	Plug
	Manufacturer	Panasonic
	Part number	AXE510127

Electrical Characteristics

Power conversion table (The display power has different names on different platforms)

Display	Phone PCB	Voltage
VDDI	VDDI	1.85V
DVDD	DVDD	1.35V
VSP	VSP	5.6V
VSN	VSN	-5.6V
GND	GND	-

b. Absolute maximum ratings

Item	Symbol	Min.	Max.	Unit	Remark
TFT					
Supply voltage (Logic)	V_{VDDI}	-0.3	+2.15	V	
Supply voltage (Digital)	V_{DVDD}	-0.3	+1.45	V	
Storage temperature	T_{stg}	-55	+125	C	
Driver supply Voltage VSP	V_{VSP}	-0.3	+6.6	V	
Operating temperature	T_{opr}	-40	+85	C	
LED Input electric current	I_{LED}	--		mA/pcs	

c. Recommended operating conditions

Item	Symbol	Min.	Typ.	Max.	Unit
LCD					
Supply voltage range VDDI	V_{VDDI}	1.75	1.85	1.95	V
Supply voltage range DVDD	V_{DVDD}	1.30	1.35	1.40	
Supply voltage range VSP	V_{VSP}	5.2	-	5.9	V
Supply voltage range VSN	V_{VSN}	-5.9	-	-5.2	V
Output voltage range low	V_{VOL}	0		$0.2 V_{VDDI}$	V
Output voltage range high	V_{VOH}	$0.8 V_{VDDI}$		V_{VDDI}	V
Input voltage range low	V_{VIL}	0		$0.3 V_{VDDI}$	V
Input voltage range high	V_{VIH}	$0.7 V_{VDDI}$		V_{IOVDD}	V
BL LED current	I_{LED}	--	20	--	mA

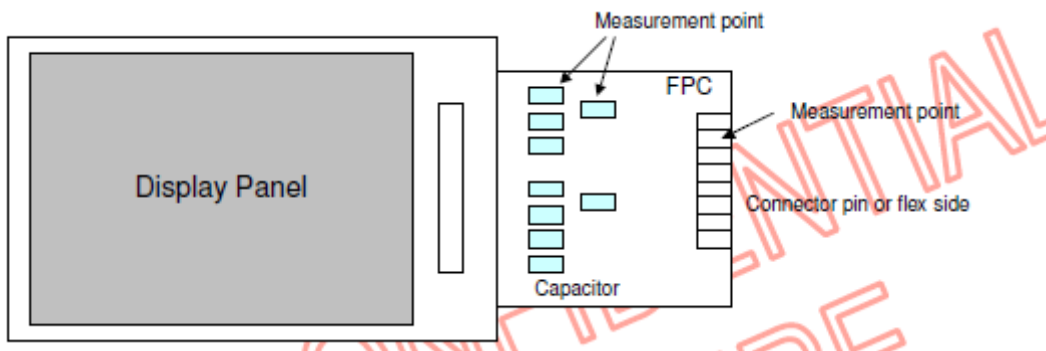

d. MIPI_DSI_CLK & Data Timing

d-1 High Speed Mode

(DVSS=DVSS1=DVSS2=AVSS=VSSAM1=VSSAM2=0V, VDDI=1.65V to 1.95V, Ta=-30 to 70 C)

Signal	Symbol	Parameter	MIN	TYP	MAX	Unit	Description
DSI-CLK+/-	$2 \times U_{INST}$	Double UI instantaneous	2	-	8	ns	4 Lane (Note 2)
DSI-CLK+/-	U_{INSTA} U_{INSTB}	UI instantaneous halves ($UI = U_{INSTA} = U_{INSTB}$)	1	-	4	ns	4 Lane (Note 2)
DSI-Dn+/-	t_{DS}	Data to clock setup time	$0.15 \times UI$	-	-	ps	
DSI-Dn+/-	t_{DH}	Data to clock hold time	$0.15 \times UI$	-	-	ps	
DSI-CLK+/-	t_{DRTCLK}	Differential rise time for clock	150	-	$0.3 \times UI$	ps	
DSI-Dn+/-	$t_{DRTDATA}$	Differential rise time for data	150	-	$0.3 \times UI$	ps	
DSI-CLK+/-	t_{DFTCLK}	Differential fall time for clock	150	-	$0.3 \times UI$	ps	
DSI-Dn+/-	$t_{DFTDATA}$	Differential fall time for data	150	-	$0.3 \times UI$	ps	

Note 1) Dn = D0, D1, D2 and D3.

Note 2) Maximum total bit rate is TBD Gbps for 24-bit data format, TBD Gbps for 18-bit data format and TBD Gbps for 16-bit data format for two DSI ports (4x2 lanes) application which support to 2160RGBx 3840 resolution.

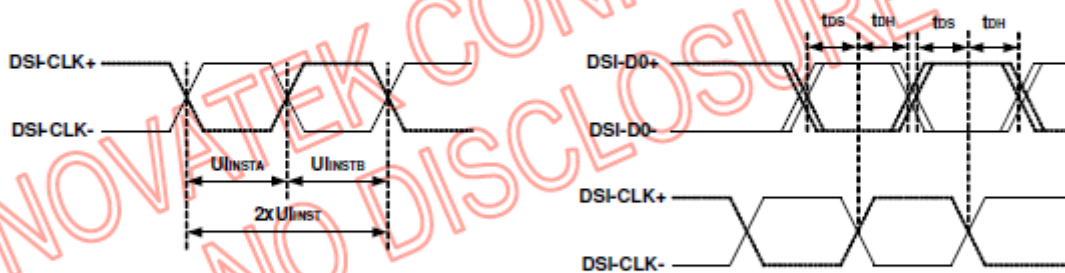
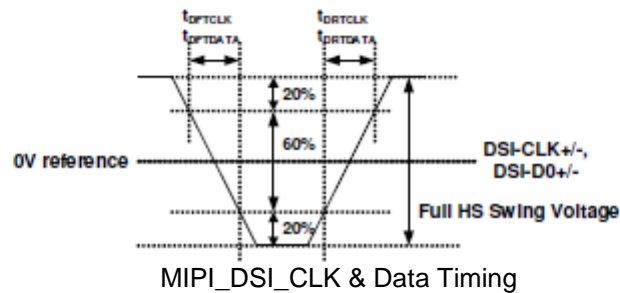

Fig. 7.3.1 DSI clock channel timing



MIPI_DSI_CLK & Data Timing

d-2 Low Power Mode

(DVSS=DVSS1=DVSS2=AVSS=VSSAM1=VSSAM2=0V, VDDI= 1.65V to 1.95V, Ta=-30 to 70 C)

Signal	Symbol	Parameter	MIN	TYP	MAX	Unit	Description
DSI-D0+/-	T_{LPXM}	Length of LP-00, LP-01, LP-10 or LP-11 periods MPU → Display Module	50	-	75	ns	Input
DSI-D0+/-	T_{LPXD}	Length of LP-00, LP-01, LP-10 or LP-11 periods Display Module → MPU	50	-	75	ns	Output
DSI-D0+/-	$T_{TA-SURED}$	Time-out before the MPU start driving	T_{LPXD}	-	$2 \times T_{LPXD}$	ns	Output
DSI-D0+/-	$T_{TA-GETD}$	Time to drive LP-00 by display module	-	$5 \times T_{LPXD}$	-	ns	Input
DSI-D0+/-	$T_{TA-GOOD}$	Time to drive LP-00 after turnaround request - MPU	-	$4 \times T_{LPXD}$	-	ns	Output

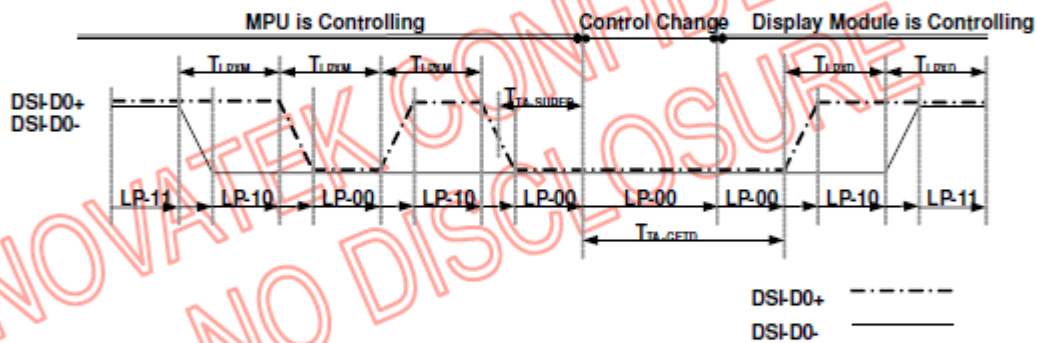
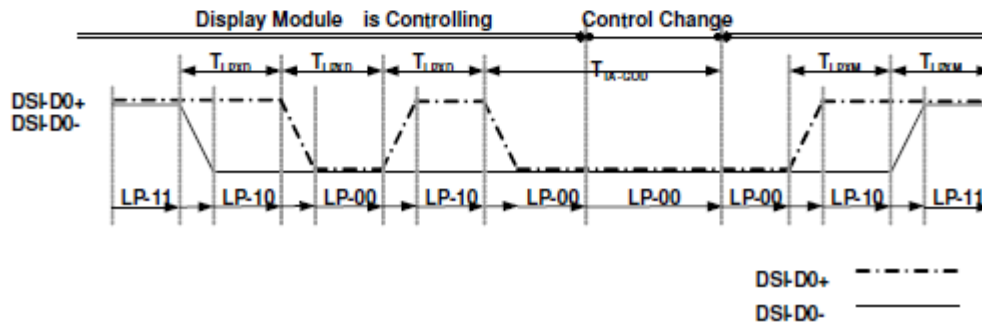

Fig. 7.3.3 Bus Turnaround (BTA) from MPU to display module Timing



e. Setting for MIPI eye

Low-level differential input voltage threshold	V_{THCLK} V_{THDATA}	DSI-CLK+/-, DSI-Dn+/-	-70	-	-	mV
High-level differential input voltage threshold	V_{THCLK} V_{THDATA}	DSI-CLK+/-, DSI-Dn+/-	-	-	70	mV

f. Power on/off sequence

f-1. Scaling Mode 60Hz setting (default)

H546UAN01.0 FHD Scaling Command mode 60Hz							
Power On Initial Sequence							
Step	LP/HS	DSI Packet Data Type	Reg. or time	Data	Description	term	
1		Reset-0			Initial condition		
2		Power Supply IOVDD (Typ1.85V)			IOVDD ON (MIPI on LP-00)		
3		Delays(ms)	>0ms		VDD1 >= DVDD during power rising	ton1	
4		Power Supply DVDD,DVDD1/2 (Typ1.35V)			DVDD,DVDD1/2 ON (MIPI on LP-00)		
5		Delays(ms)	>0ms		EXT_DVDD_EN-1: DVDD >= AVDD during power rising	ton2	
6		Power Supply AVDD (Typ5.6V)			AVDD ON (MIPI on LP-00)		
7		Delays(ms)	>0ms		BTM-0: AVDDI >= AVEE during power rising	ton3	
8		Power Supply AVEE (Typ 5.6V)			AVEE ON (MIPI on LP-00)		
9		Delays(ms)	>10ms(t4)		After Wait until DVDD,DVDD1/2 power stable	t4	
10		MIPI -> LP11			(MIPI -> LP11)		
11		Delays(ms)	<10ms(-t4)			t6	
12		Reset-1			RESX High (MIPI on LP-11)		
13		Delays(ms)	>10ms			#1	
14		Reset-0			RESX go Low (MIPI on LP-11)		
15		Delay(ns)	>10us			t7	
16		Reset-1			RESX go High (MIPI on LP-11)		
17		Delays(ms)	>10ms		[Automatic] NVM Auto load->Sleep Mode On	t5	
18		Tx Initial Setting					
IC Porch Setting							
19	LP	[B9h] DCS Write, 4 Parameter	FFh	AAh, 55h, A5h, 80h	Enable Test Command		
20	LP	[15h] DCS Write, 1 Parameter	6Fh	01h	Insert blanking Image between Display ON and Video Input		
21	LP	[15h] DCS Write, 1 Parameter	F3h	10h			
22	LP	[B9h] DCS Write, 4 Parameter	FFh	AAh, 55h, A5h, 00h	Disable Test Command		
23	LP	[15h] DCS Write, 1 Parameter	58h	01h	Scaling Up Function Control(enable)		
24	LP	[15h] DCS Write, 1 Parameter	90h	00h	Set Compression Method(disable)		
25	LP	[B9h] DCS Write, 5 Parameter	F0h	55h, AAh, 52h, 08h, 00h	CM02 Page0		
26	LP	[15h] DCS Write, 1 Parameter	B4h	01h	Set MIPI Display Mode(Command Mode, GRAM access enable)		
27	LP	[15h] DCS Write, 1 Parameter	C9h	01h	Scaling Up Mode Control(1080x1920 -> 2160x3840 (Bilinear))		
27	LP	[15h] DCS Write, 1 Parameter	C9h	11h	Scaling Up Mode Control(1080x1920 -> 2160x3840 (Duplicate))		
28	LP	[B9h] DCS Write,15 Parameter	BDh	00h, AAh, 12h, 24h, 00h, 01h, 56h, 00h, 00h, 01h, 00h, 00h, 00h, 00h, 07h	Command Mode 60Hz Normal mode(OTP value),Dynamic frame 47.5Hz		
29	LP	[B9h] DCS Write,11 Parameter	BEh	00h, AAh, 12h, 24h, 00h, 01h, 56h, 00h, 00h, 01h, 00h	Command Mode 60Hz Idle mode(OTP value)		
30	LP	[B9h] DCS Write, 5 Parameter	CDh	02h, 00h, 00h, 0Eh, 00h,	use Vsync pin by TE(it's OTP Value after SP1)		
31	LP	[B9h] DCS Write, 5 Parameter	F0h	55h, AAh, 52h, 08h, 03h	CM02 Page3		
32	LP	[B9h] DCS Write, 4 Parameter	00h	0Ah, 0Ah, 0Ah, 0Ah	EQ Control for Signal Group CLK(OTP value in TP,this CMD use before AP2)		
33	LP	[B9h] DCS Write, 4 Parameter	01h	0Ah, 0Ah, 0Ah, 0Ah	EQ Control for Signal Group MUX(OTP value in TP,this CMD use before AP2)		
34	LP	[B9h] DCS Write, 5 Parameter	BAh	02h, 00h, 90h, 00h, 00h	Control for Signal Type CLK01(OTP value in TP,this CMD use before AP2)		
35	LP	[B9h] DCS Write, 5 Parameter	BBh	02h, 00h, 90h, 00h, 00h	Control for Signal Type CLK02(OTP value in TP,this CMD use before AP2)		
36	LP	[B9h] DCS Write, 5 Parameter	F0h	55h, AAh, 52h, 08h, 07h	CM02 Page7		
37	LP	[15h] DCS Write, 1 Parameter	E3h	07h	spr_mode=1		
38	LP	[15h] DCS Write, 1 Parameter	EFh	02h	spr_mode_sel=2		
39	LP	If customer need, please add initial command in here.					
40	LP	[15h] DCS Write, 1 Parameter	35h	00h	TE enable		
41	LP	[05h] DCS Write, No Parameter	11h		Sleep Out		
42		Wait 4frame	(70ms in 60Hz case)				
43	LP	[05h] DCS Write, No Parameter	29h		Display On		
44		Tx High Speed Mode Setting(Display data transfer)				Image Write	
45		Delays(ms)	>0ms		[Automatic] Display On	t9	
46		Backlight on					

f-2. Scaling Mode 47.4Hz setting (for reference)

H546UAN01.0 FHD Scaling Command mode 47.5Hz							
Power On Initial Sequence							
Step	LP/HS	DSI Packet Data Type	Reg. or time	Data	Description	term	
1		Reset-0			Initial condition		
2		Power Supply IOVDD (Typ1.85V)			IOVDD ON (MIPI on LP-00)		
3		Delays(ms)	>0ms		VDD1 >= DVDD during power rising	ton1	
4		Power Supply DVDD,DVDD1/2 (Typ1.35V)			DVDD,DVDD1/2 ON (MIPI on LP-00)		
5		Delays(ms)	>0ms		EXT_DVDD_EN-1: DVDD >= AVDD during power rising	ton2	
6		Power Supply AVDD (Typ5.6V)			AVDD ON (MIPI on LP-00)		
7		Delays(ms)	>0ms		BTM-0: AVDDI >= AVEE during power rising	ton3	
8		Power Supply AVEE (Typ 5.6V)			AVEE ON (MIPI on LP-00)		
9		Delays(ms)	>10ms(t4)		After Wait until DVDD,DVDD1/2 power stable	t4	
10		MIPI -> LP11			(MIPI -> LP11)		
11		Delays(ms)	<10ms(-t4)			t6	
12		Reset-1			RESX High (MIPI on LP-11)		
13		Delays(ms)	>10ms			#1	
14		Reset-0			RESX go Low (MIPI on LP-11)		
15		Delay(ns)	>10us			t7	
16		Reset-1			RESX go High (MIPI on LP-11)		
17		Delays(ms)	>10ms		[Automatic] NVM Auto load->Sleep Mode On	t5	
18		Tx Initial Setting					
IC Porch Setting							
19	LP	[B9h] DCS Write, 4 Parameter	FFh	AAh, 55h, A5h, 80h	Enable Test Command		
20	LP	[15h] DCS Write, 1 Parameter	6Fh	01h	Insert blanking Image between Display ON and Video Input		
21	LP	[15h] DCS Write, 1 Parameter	F3h	10h			
22	LP	[B9h] DCS Write, 4 Parameter	FFh	AAh, 55h, A5h, 00h	Disable Test Command		
23	LP	[15h] DCS Write, 1 Parameter	58h	01h	Scaling Up Function Control(enable)		
24	LP	[15h] DCS Write, 1 Parameter	90h	00h	Set Compression Method(disable)		
25	LP	[B9h] DCS Write, 5 Parameter	F0h	55h, AAh, 52h, 08h, 00h	CM02 Page0		
26	LP	[15h] DCS Write, 1 Parameter	B4h	01h	Set MIPI Display Mode(Command Mode, GRAM access enable)		
27	LP	[15h] DCS Write, 1 Parameter	C9h	01h	Scaling Up Mode Control(1080x1920 -> 2160x3840 (Bilinear))		
27	LP	[15h] DCS Write, 1 Parameter	C9h	11h	Scaling Up Mode Control(1080x1920 -> 2160x3840 (Duplicate))		
28	LP	[B9h] DCS Write,15 Parameter	BDh	00h, 07h, 12h, 24h, 00h, 01h, A6h, 00h, 00h, 01h, 42h, 00h, 00h, 00h, 07h	Command Mode 47.5Hz Normal mode		
29	LP	[B9h] DCS Write,11 Parameter	BEh	00h, 07h, 12h, 24h, 00h, 01h, A6h, 00h, 00h, 01h, 42h,	Command Mode 47.5Hz Idle mode		
30	LP	[B9h] DCS Write, 5 Parameter	CDh	02h, 00h, 00h, 0Eh, 00h,	use Vsync pin by TE(it's OTP Value after SP1)		
31	LP	[B9h] DCS Write, 5 Parameter	F0h	55h, AAh, 52h, 08h, 03h	CM02 Page3		
32	LP	[B9h] DCS Write, 4 Parameter	00h	0Ah, 0Ah, 0Ah, 0Ah	EQ Control for Signal Group CLK(OTP value in TP,this CMD use before AP2)		
33	LP	[B9h] DCS Write, 4 Parameter	01h	0Ah, 0Ah, 0Ah, 0Ah	EQ Control for Signal Group MUX(OTP value in TP,this CMD use before AP2)		
34	LP	[B9h] DCS Write, 5 Parameter	BAh	02h, 00h, 90h, 00h, 00h	Control for Signal Type CLK01(OTP value in TP,this CMD use before AP2)		
35	LP	[B9h] DCS Write, 5 Parameter	BBh	02h, 00h, 90h, 00h, 00h	Control for Signal Type CLK02(OTP value in TP,this CMD use before AP2)		
36	LP	[B9h] DCS Write, 5 Parameter	F0h	55h, AAh, 52h, 08h, 07h	CM02 Page7		
37	LP	[15h] DCS Write, 1 Parameter	E3h	07h	spr_mode=1		
38	LP	[15h] DCS Write, 1 Parameter	EFh	02h	spr_mode_sel=2		
39	LP	If customer need, please add initial command in here.					
40	LP	[15h] DCS Write, 1 Parameter	35h	00h	TE enable		
41	LP	[05h] DCS Write, No Parameter	11h		Sleep Out		
42		Wait 4frame	(69ms in 47.5Hz case)				
43	LP	[05h] DCS Write, No Parameter	29h		Display On		
44		Tx High Speed Mode Setting(Display data transfer)				Image Write	
45		Delays(ms)	>0ms		[Automatic] Display On	t9	
46		Backlight on					

- 3 Input power (BTM="0") with external DVDD (EXT_DVDD_EN="1"):
 VDDI=1.65~1.95V, DVDD=1.1~1.3V, AVDD=4.5~6.3V, AVEE=-4.5~-6.3V

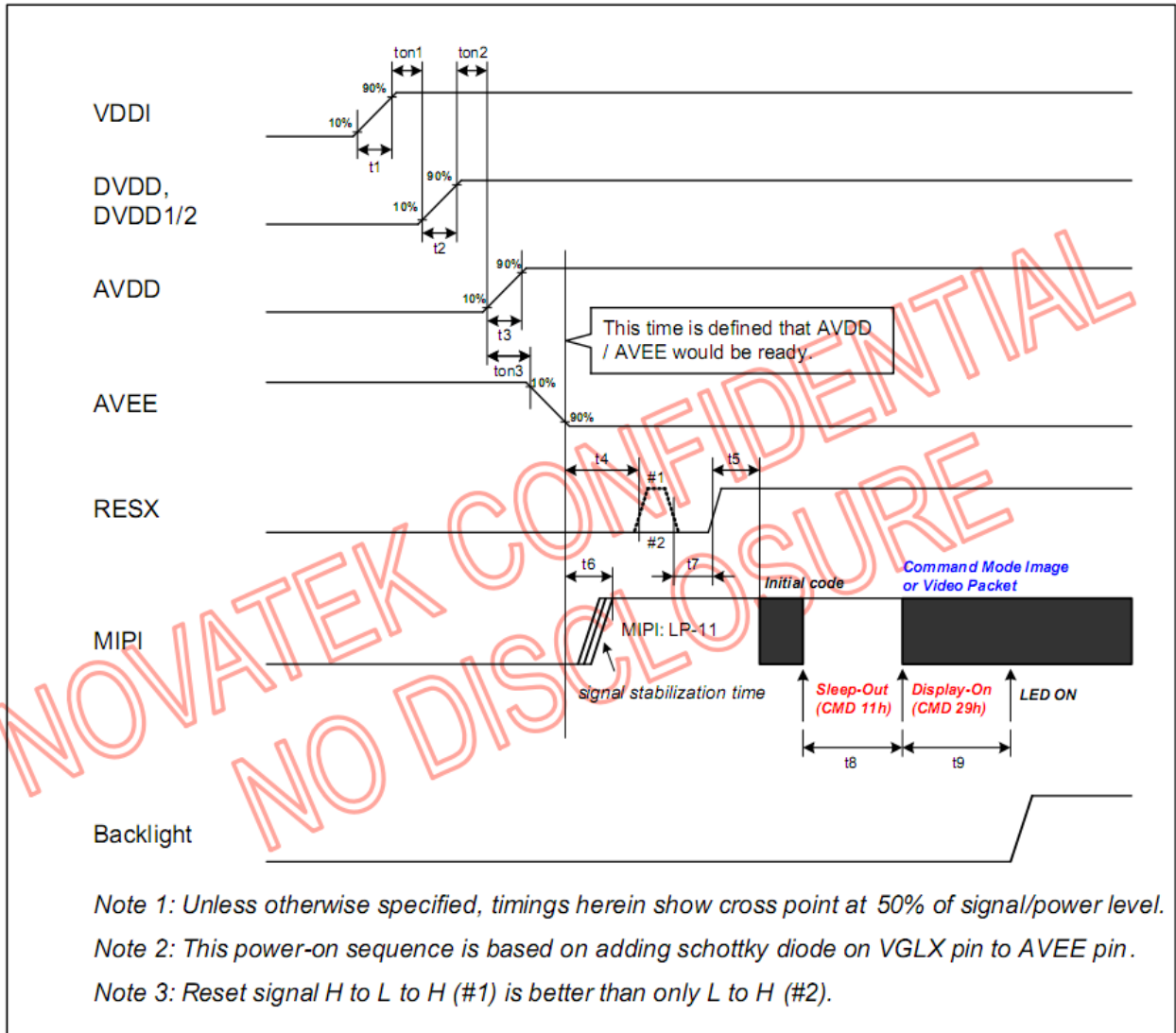

Symbol	Value			Unit	Remark
	Min.	Typ.	Max.		
ton1	0	-	-	ms	
ton2	0	-	-	ms	
ton3	0	-	-	ms	BTM=0: AVDD ≥ AVEE during power rising BTM=1: VGH ≥ AVDD during power rising
ton4	0	-	-	ms	VGH ≥ VGLX during power rising
ton5	0	-	-	ms	VGLX ≥ AVEE during power rising
t1	0.2	-	5	ms	
t2	0.2	-	2	ms	
t3	0.2	-	5	ms	
t4	10	-	-	ms	
t5	10	-	-	ms	
t6	0	-	t4	ms	
t7	10	-	-	us	
t8	120	-	-	ms	
t9	0	-	-	ms	

f-3. FBC2.0 60Hz setting (default)

H546UAN01.0 FBC2.0 Command mode tought RAM 60Hz							
Power On Initial Sequence							
Step	LP/HS	DSI Packet Data Type	Reg. or time	Data	Description	term	
1			Reset=0		Initial condition		
2		Power Supply IOVDD (Typ1.85V)			IOVDD ON (MIPI on LP:00)		
3		Delay(ms)	>0ms		VDDI >= DVDD during power rising	ton1	
4		Power Supply DVDD,DVDD1/2 (Typ1.35V)			DVDD,DVDD1/2 ON (MIPI on LP:00)		
5		Delay(ms)	>0ms		EXT_DVDD_EN=1: DVDD >= AVDD during power rising	ton2	
6		Power Supply AVDD (Typ5.6V)			AVDD ON (MIPI on LP:00)		
7		Delay(ms)	>0ms		BTM=0: (AVDD) >= (AVEE) during power rising	ton3	
8		Power Supply AVEE (Typ 5.6V)			AVEE ON (MIPI on LP:00)		
9		Delay(ms)	>10ms(t4)		After Wait until DVDD,DVDD1/2 power stable	t4	
10		MIPI -> LP11			(MIPI -> LP11)		
11		Delay(ms)	<10ms(<t4)			t6	
12		Reset=1			RESX High (MIPI on LP:11)		
13		Delay(ms)	>10ms			#1	
14		Reset=0			RESX go Low (MIPI on LP:11)		
15		Delay(us)	>10us			t7	
16		Reset=1			RESX go High (MIPI on LP:11)		
17		Delay(ms)	>10ms		[Automatic] NVM Auto load->Sleep Mode On	t5	
18			Tx Initial Setting				
IC Porch Setting							
19	LP	[39h] DCS Write, 4 Parameter	FFh	AAh, 55h, A5h, 80h	Enable Test Command		
20	LP	[15h] DCS Write, 1 Parameter	6Fh	01h	Insert blanking Image between Display ON and Video Input		
21	LP	[15h] DCS Write, 1 Parameter	F3h	10h	Disable Test Command		
22	LP	[39h] DCS Write, 4 Parameter	FFh	AAh, 55h, A5h, 00h	Scaling Up Function Control(Disable)		
23	LP	[15h] DCS Write, 1 Parameter	58h	00h	Set Compression Method(FBC Mode)		
24	LP	[15h] DCS Write, 1 Parameter	90h	02h	CM02 Page0		
25	LP	[39h] DCS Write, 5 Parameter	F0h	55h, AAh, 52h, 08h, 00h	Set MIPI Display Mode(Command Mode, GRAM access enable)		
26	LP	[15h] DCS Write, 1 Parameter	04h	01h	Command Mode 60Hz Normal mode(OTP value),Dynamic frame 47.5Hz		
27	LP	[39h] DCS Write,15 Parameter	80h	00h, AAh, 12h, 24h, 00h, 01h, 56h, 00h, 00h, 01h, 00h, 00h, 00h, 00h, 07h	Command Mode 60Hz Idle mode(OTP value)		
28	LP	[39h] DCS Write,11 Parameter	8Eh	00h, AAh, 12h, 24h, 00h, 01h, 56h, 00h, 00h, 01h, 00h	Command Mode 60Hz Idle mode(OTP value)		
29	LP	[15h] DCS Write, 1 Parameter	C9h	00h	Scaling Up Mode Control(1440x2560 -> 2160x3840)		
29	LP	[15h] DCS Write, 1 Parameter	C9h	01h	Scaling Up Mode Control(1080x1920 -> 2160x3840 (Bilinear))		
29	LP	[15h] DCS Write, 1 Parameter	C9h	11h	Scaling Up Mode Control(1080x1920 -> 2160x3840 (Duplicate))		
30	LP	[39h] DCS Write, 5 Parameter	C0h	02h, 00h, 00h, 0Eh, 00h,	use Vsync pin by TE(it's OTP Value after SP1)		
31	LP	[39h] DCS Write, 5 Parameter	F0h	55h, AAh, 52h, 08h, 03h	CM02 Page3		
32	LP	[39h] DCS Write, 4 Parameter	00h	0Ah, 0Ah, 0Ah, 0Ah	EQ Control for Signal Group CLK(OTP value in TP,this CMD use before AP2)		
33	LP	[39h] DCS Write, 4 Parameter	01h	0Ah, 0Ah, 0Ah, 0Ah	EQ Control for Signal Group MUX(OTP value in TP,this CMD use before AP2)		
34	LP	[39h] DCS Write, 5 Parameter	8Ah	62h, 00h, 90h, 00h, 00h	Control for Signal Type CLK01(OTP value in TP,this CMD use before AP2)		
35	LP	[39h] DCS Write, 5 Parameter	8Bh	62h, 00h, 90h, 00h, 00h	Control for Signal Type CLK02(OTP value in TP,this CMD use before AP2)		
36	LP	[39h] DCS Write, 5 Parameter	F0h	55h, AAh, 52h, 08h, 07h	CM02 Page7		
37	LP	[15h] DCS Write, 1 Parameter	E3h	07h	spr_mode=1		
38	LP	[15h] DCS Write, 1 Parameter	F7h	02h	spr_mode_sel=2		
39	LP	If customer need, please add initial command in here.					
40	LP	[15h] DCS Write, 1 Parameter	35h	00h	TE enable		
41	LP	[05h] DCS Write, No Parameter	11h		Sleep Out		
42		Wait 4frame	(70ms in 60Hz case)				
43	LP	[05h] DCS Write, No Parameter	29h		Display On		
44		Tx High Speed Mode Setting(Display data transfer)				Image Write	
45		Delay(ms)	>0ms		[Automatic] Display On	t8	
46		Backlight on					

f-4. FBC2.0 47.4Hz setting (for reference)

H546UAN01.0 FBC2.0 Command mode tought RAM 47.5Hz							
Power On Initial Sequence							
Step	LP/HS	DSI Packet Data Type	Reg. or time	Data	Description	term	
1			Reset=0		Initial condition		
2		Power Supply IOVDD (Typ1.85V)			IOVDD ON (MIPI on LP:00)		
3		Delay(ms)	>0ms		VDDI >= DVDD during power rising	ton1	
4		Power Supply DVDD,DVDD1/2 (Typ1.35V)			DVDD,DVDD1/2 ON (MIPI on LP:00)		
5		Delay(ms)	>0ms		EXT_DVDD_EN=1: DVDD >= AVDD during power rising	ton2	
6		Power Supply AVDD (Typ5.6V)			AVDD ON (MIPI on LP:00)		
7		Delay(ms)	>0ms		BTM=0: (AVDD) >= (AVEE) during power rising	ton3	
8		Power Supply AVEE (Typ 5.6V)			AVEE ON (MIPI on LP:00)		
9		Delay(ms)	>10ms(t4)		After Wait until DVDD,DVDD1/2 power stable	t4	
10		MIPI -> LP11			(MIPI -> LP11)		
11		Delay(ms)	<10ms(<t4)			t6	
12		Reset=1			RESX High (MIPI on LP:11)		
13		Delay(ms)	>10ms			#1	
14		Reset=0			RESX go Low (MIPI on LP:11)		
15		Delay(us)	>10us			t7	
16		Reset=1			RESX go High (MIPI on LP:11)		
17		Delay(ms)	>10ms		[Automatic] NVM Auto load->Sleep Mode On	t5	
18			Tx Initial Setting				
IC Porch Setting							
19	LP	[39h] DCS Write, 4 Parameter	FFh	AAh, 55h, A5h, 80h	Enable Test Command		
20	LP	[15h] DCS Write, 1 Parameter	6Fh	01h	Insert blanking Image between Display ON and Video Input		
21	LP	[15h] DCS Write, 1 Parameter	F3h	10h	Disable Test Command		
22	LP	[39h] DCS Write, 4 Parameter	FFh	AAh, 55h, A5h, 00h	Scaling Up Function Control(Disable)		
23	LP	[15h] DCS Write, 1 Parameter	58h	00h	Set Compression Method(FBC Mode)		
24	LP	[15h] DCS Write, 1 Parameter	90h	02h	CM02 Page0		
25	LP	[39h] DCS Write, 5 Parameter	F0h	55h, AAh, 52h, 08h, 00h	Set MIPI Display Mode(Command Mode, GRAM access enable)		
26	LP	[15h] DCS Write, 1 Parameter	04h	01h	Command Mode 47.5Hz Normal mode		
27	LP	[39h] DCS Write,15 Parameter	80h	00h, D7h, 12h, 24h, 00h, 01h, AEh, 00h, 00h, 01h, 42h, 00h, 00h, 00h, 07h	Command Mode 47.5Hz Idle mode		
28	LP	[39h] DCS Write,11 Parameter	8Eh	00h, D7h, 12h, 24h, 00h, 01h, AEh, 00h, 00h, 01h, 42h,	Command Mode 47.5Hz Idle mode		
29	LP	[15h] DCS Write, 1 Parameter	C9h	00h	Scaling Up Mode Control(1440x2560 -> 2160x3840)		
29	LP	[15h] DCS Write, 1 Parameter	C9h	01h	Scaling Up Mode Control(1080x1920 -> 2160x3840 (Bilinear))		
29	LP	[15h] DCS Write, 1 Parameter	C9h	11h	Scaling Up Mode Control(1080x1920 -> 2160x3840 (Duplicate))		
30	LP	[39h] DCS Write, 5 Parameter	C0h	02h, 00h, 00h, 0Eh, 00h,	use Vsync pin by TE(it's OTP Value after SP1)		
31	LP	[39h] DCS Write, 5 Parameter	F0h	55h, AAh, 52h, 08h, 03h	CM02 Page3		
32	LP	[39h] DCS Write, 4 Parameter	00h	0Ah, 0Ah, 0Ah, 0Ah	EQ Control for Signal Group CLK(OTP value in TP,this CMD use before AP2)		
33	LP	[39h] DCS Write, 4 Parameter	01h	0Ah, 0Ah, 0Ah, 0Ah	EQ Control for Signal Group MUX(OTP value in TP,this CMD use before AP2)		
34	LP	[39h] DCS Write, 5 Parameter	8Ah	62h, 00h, 90h, 00h, 00h	Control for Signal Type CLK01(OTP value in TP,this CMD use before AP2)		
35	LP	[39h] DCS Write, 5 Parameter	8Bh	62h, 00h, 90h, 00h, 00h	Control for Signal Type CLK02(OTP value in TP,this CMD use before AP2)		
36	LP	[39h] DCS Write, 5 Parameter	F0h	55h, AAh, 52h, 08h, 07h	CM02 Page7		
37	LP	[15h] DCS Write, 1 Parameter	E3h	07h	spr_mode=1		
38	LP	[15h] DCS Write, 1 Parameter	F7h	02h	spr_mode_sel=2		
39	LP	If customer need, please add initial command in here.					
40	LP	[15h] DCS Write, 1 Parameter	35h	00h	TE enable		
41	LP	[05h] DCS Write, No Parameter	11h		Sleep Out		
42		Wait 4frame	(69ms in 47.5Hz case)				
43	LP	[05h] DCS Write, No Parameter	29h		Display On		
44		Tx High Speed Mode Setting(Display data transfer)				Image Write	
45		Delay(ms)	>0ms		[Automatic] Display On	t8	
46		Backlight on					

f-5. Power off

Power Off Sequence							
Step	LP/HS	DSI Packet Data Type	Reg. or time	Data	Description	term	
1		Backlight off					
2		Delay(ms)	>0ms				
3	HS	[05h] DCS Write, No Parameter	28h		Display Off		
4		Delay(ms)	>0ms			t14	
5	HS	[05h] DCS Write, No Parameter	10h		Sleep In		
6		Delay(ms)	>100ms(t15)		Hsync/Vsync signals should be send after Sleep In command	t15	
7		Mipi data transfer Stop and MIPI -> LP00					
8		Delay(ms)	<100ms(t13)			t13	
9		Reset=0					
10		Delay(ms)	>0ms		RESX go Low		
11		AVEE (Typ+5.6V) OFF					
12		Delay(ms)	>0ms		Wait until AVEE- power stable	tof3	
13		AVDD (Typ+5.6V) OFF					
14		Delay(ms)	>0ms		Wait until AVDD+ power stable	tof2	
15		DVDD, DVDD1/2 (Typ1.35V) OFF					
16		Delay(ms)	>0ms		Wait until DVDD+ power stable	tof1	
17		IOVDD OFF(Typ1.85V) OFF					

- 3 Input power (BTM="0") with external DVDD (EXT_DVDD_EN="1"):
 VDDI=1.65~1.95V, DVDD=1.1~1.3V, AVDD=4.5~6.3V, AVEE=-4.5~-6.3V

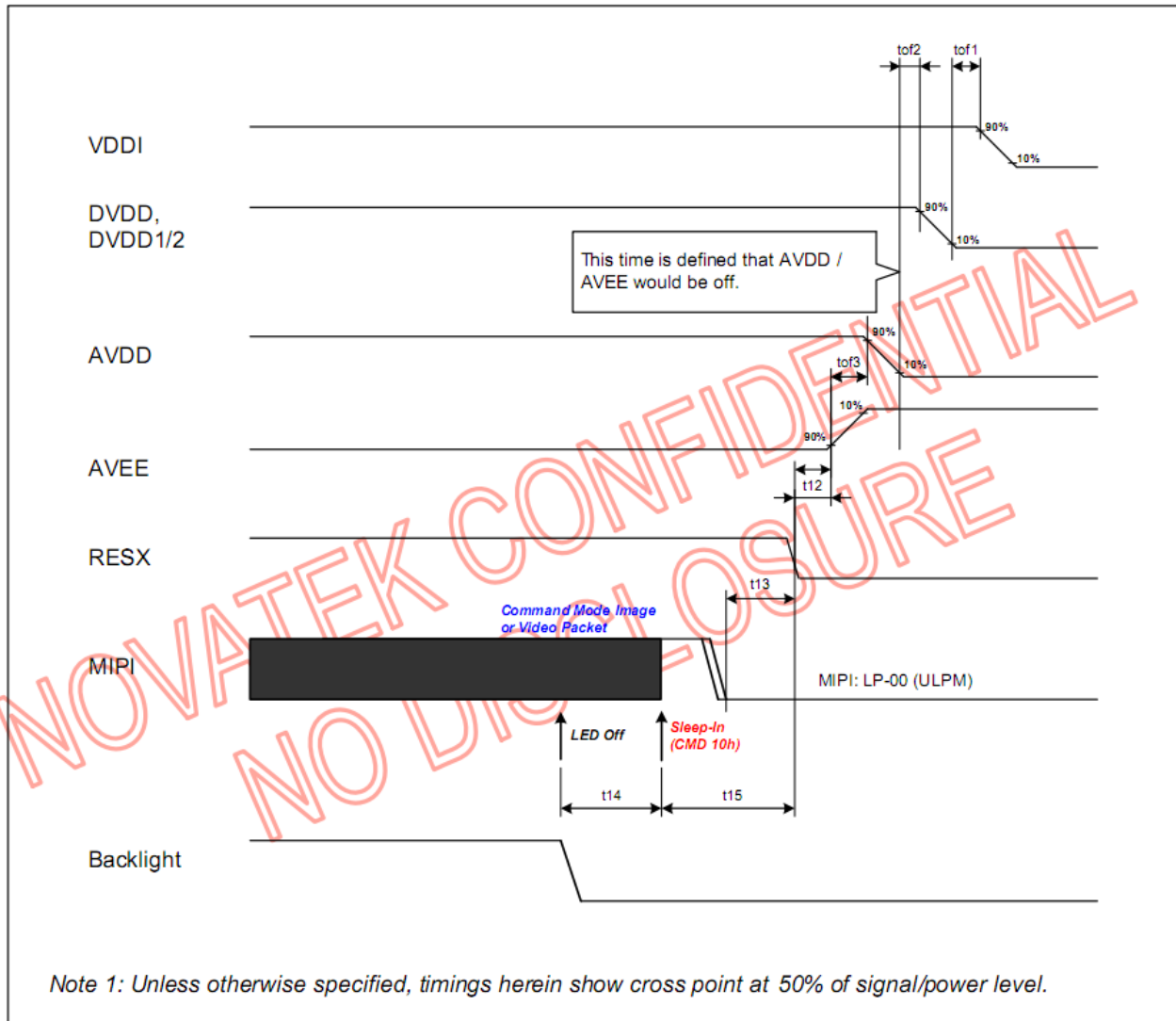

Symbol	Value			Unit	Remark
	Min.	Typ.	Max.		
tof1	0	-	-	ms	
tof2	0	-	-	ms	
tof3	0	-	-	ms	
tof4	0	-	-	ms	
tof5	0	-	-	ms	
t12	0	-	-	ms	
t13	0	-	-	ms	
t14	0	-	-	ms	
t15	100			ms	

g. Power consumption*

Parameter	Min.	Typ.	Max.	Unit
White Pattern	-	280	(332)	mW
Black Pattern	-	250	(295)	mW
R Pattern (worse pattern)	-	550	(605)	mW
G Pattern (worse pattern)	-	550	(605)	mW
B Pattern (worse pattern)	-	550	(605)	mW

* Base on TP sample measurement (MUX EQ & Timing ON)

* Max value is based on +5 σ , still need to monitor

h. Backlight Power consumption

Parameter	Min.	Typ.	Max.	Unit
Backlight power consumption	-	1026	-	mW

FPC circuit diagram [LCD FPC]

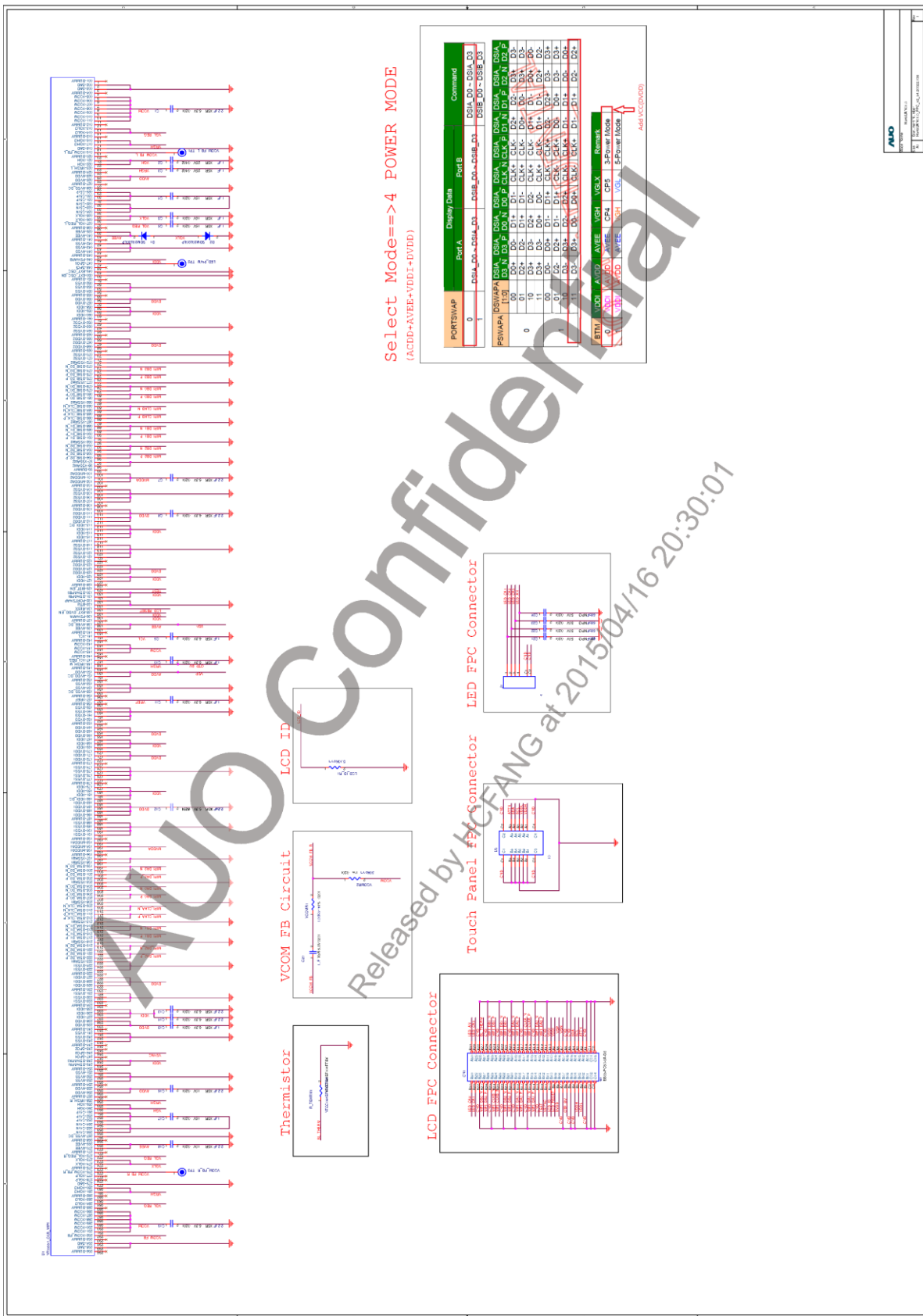

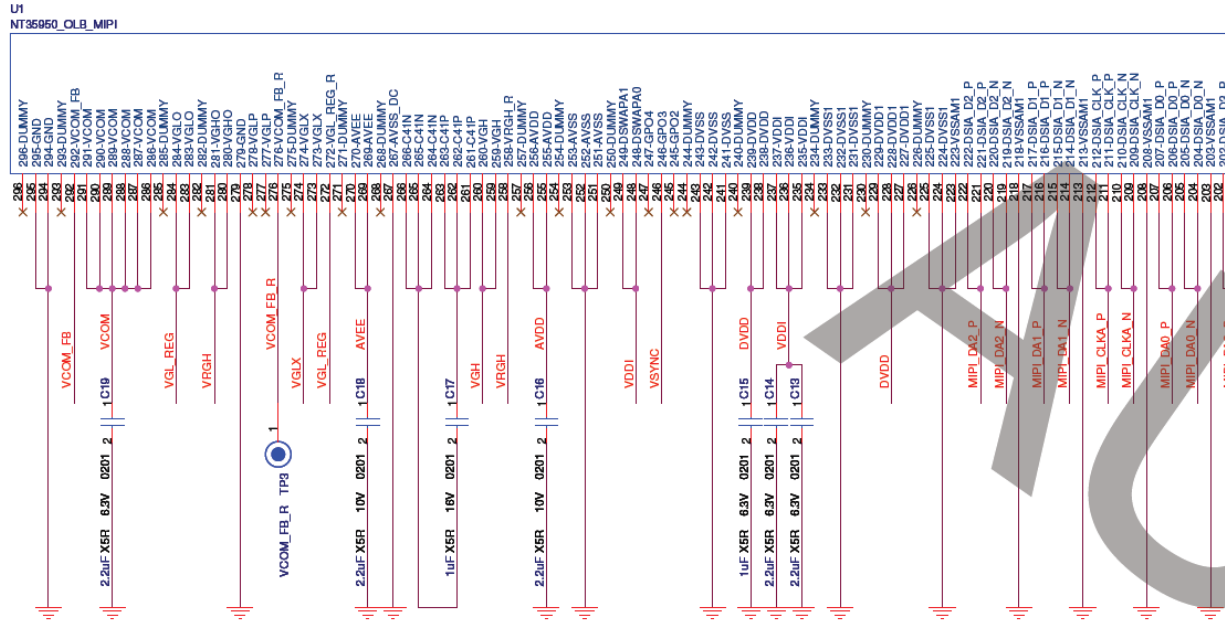
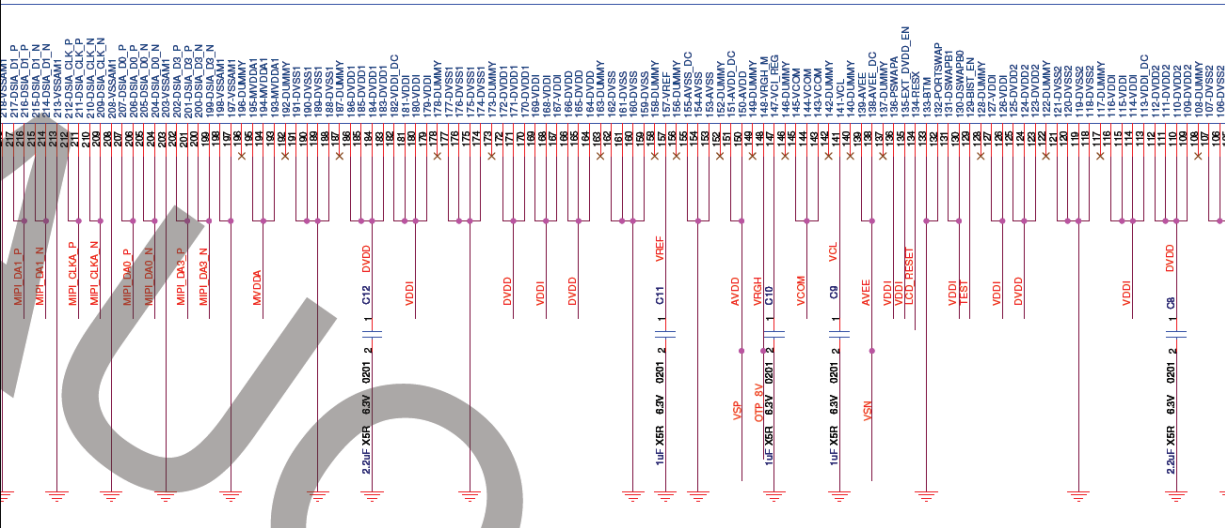
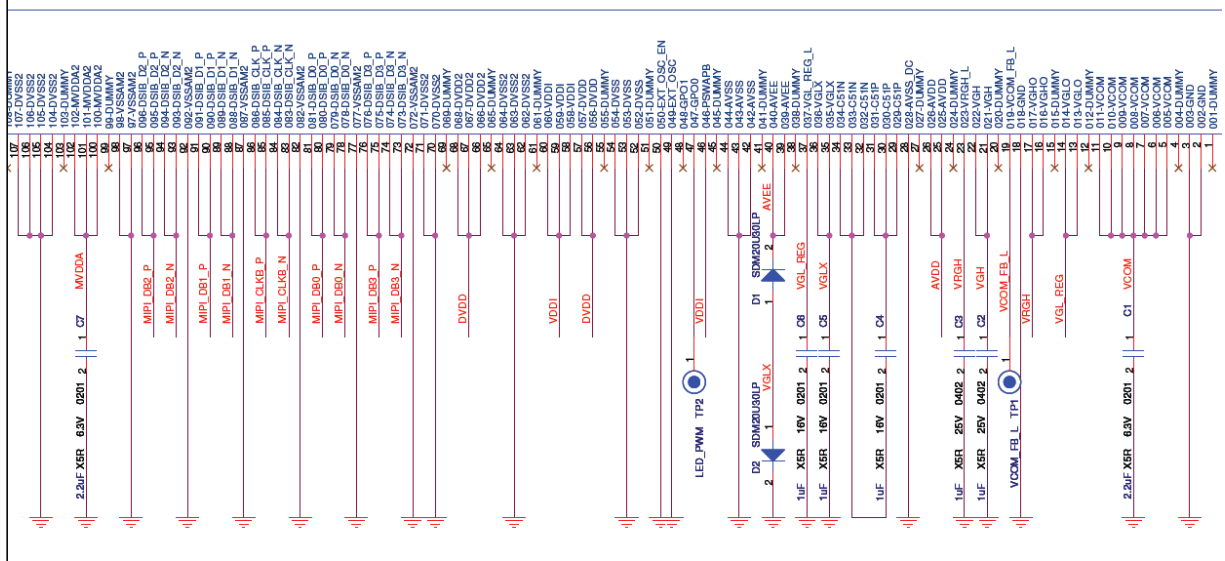

Select Mode==>4 POWER MODE (ACDD+AVEE+VDDI+DVDD)

PORTSWAP	Display Data								Command			
	Port A				Port B							
0	DSIA_D0 ~ DSIA_D3				DSIB_D0 ~ DSIB_D3				DSIA_D0 ~ DSIA_D3			
1	DSIA_D0 ~ DSIA_D3				DSIB_D0 ~ DSIB_D3				DSIB_D0 ~ DSIB_D3			

PSWAPA	DSWAPA [1:0]	DSIA_D3_N	DSIA_D3_P	DSIA_D0_N	DSIA_D0_P	DSIA_CLK_N	DSIA_CLK_P	DSIA_D1_N	DSIA_D1_P	DSIA_D2_N	DSIA_D2_P
0	00	D0+	D0-	D1+	D1-	CLK+	CLK-	D2+	D2-	D3+	D3-
	01	D2+	D2-	D1+	D1-	CLK+	CLK-	D0+	D0-	D3+	D3-
	10	D3+	D3-	D2+	D2-	CLK+	CLK-	D1+	D1-	D0+	D0-
	11	D3+	D3-	D0+	D0-	CLK+	CLK-	D1+	D1-	D2+	D2-
1	00	D0-	D0+	D1-	D1+	CLK-	CLK+	D2-	D2+	D3-	D3+
	01	D2-	D2+	D1-	D1+	CLK-	CLK+	D0-	D0+	D3-	D3+
	10	D3-	D3+	D2-	D2+	CLK-	CLK+	D1-	D1+	D0-	D0+
	11	D3-	D3+	D0-	D0+	CLK-	CLK+	D1-	D1+	D2-	D2+

BTM	VDDI	AVDD	AVEE	VGH	VGLX	Remark
0	VDDI	AVDD	AVEE	CP4	CP5	3-Power Mode
1	VDDI	AVDD	AVEE	VGH	VGL	5-Power Mode

Add VCC(DVDD)

Thermistor

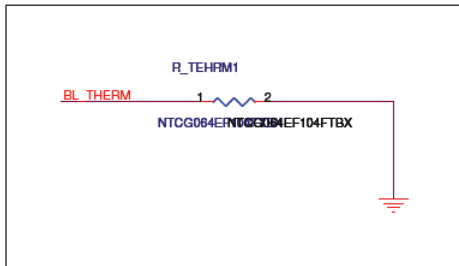

VCOM FB Circuit



LCD FPC Connector

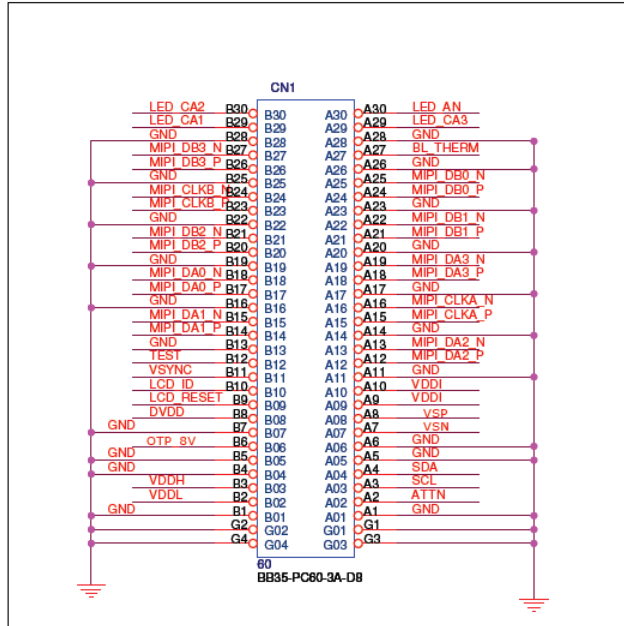
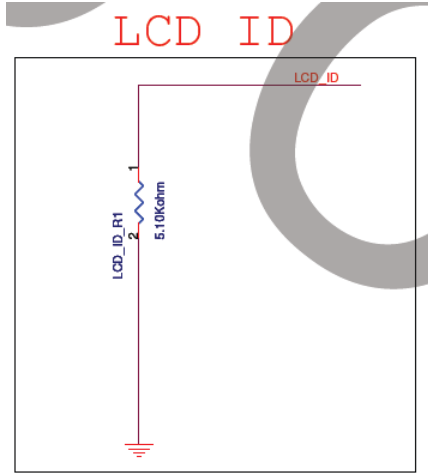

Touch Panel FPC Connector

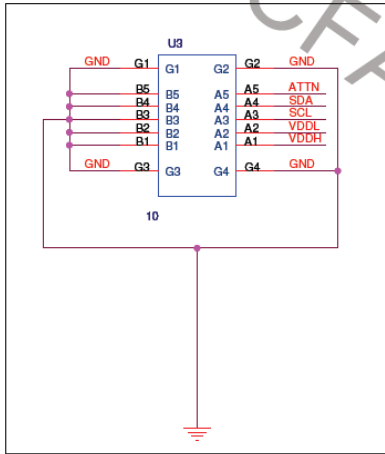

LED FPC Connector

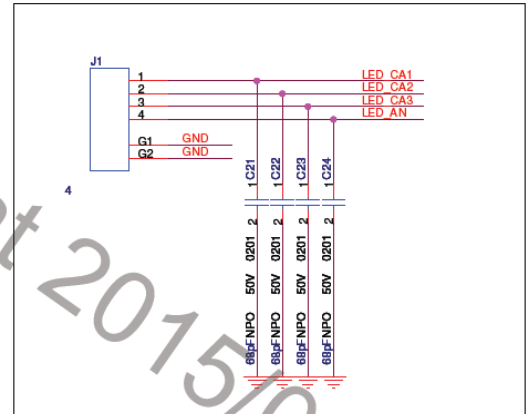

Display Driver Chip

The display driver chip is a Novatek, N35950 mounted directly onto the glass substrate by COG. And for detailed information please refer to [Ref 1].

The FPC is heat sealed to the TFT. The backlight flex is ZIF type connecting with Main FPC. The Main FPC carries external components such as resistors and capacitors.

Dendrite Growth (metallic growth between pads in the presence of moisture and an electrical bias) is not allowed.

Backlight

The backlight consists of 18 white LEDs coupled into a light guide. The even illuminated area covers at least the LCD active area.

a. White LEDs

6 LEDs in series for a group, and 3 groups do the parallel. The LEDs are bonded to the backlight flex.

Parameter	Value
Number of LED	18
LED Part Number	NSSW306F-HG
LED Vendor	Nichia
LED voltage	2.85 v (typ.)

* Please provide LED specification for reference [Ref 2]

C. Optical Specification

General condition

Item	Symbol	Conditions	Specifications			Unit	
			Min.	Typ	Max.		
Viewing Angle	A	CR \geq 100	0° (12 o'clock)	-	70	-	°
			90° (3 o'clock)	-	70	-	°
			180° (6 o'clock)	-	70	-	°
			270° (9 o'clock)	-	70	-	°
Luminance [White picture](w/o TP)	L	I=20mA(rms)	All white picture	400	500	-	cd/m ²
Contrast Ratio(DBC close)	CRT	TFT + BLON	T = +25°C	-	1000	-	-
Chromaticity (sRGB)	White	u _W v _W	Display: White Backlight: On	0.170	0.190	0.210	
				0.427	0.447	0.472	
	Red	u _R v _R	Display: Red Backlight: On	0.469	0.499	0.529	
				0.492	0.522	0.552	
	Green	u _G v _G	Display: Green Backlight: On	0.072	0.102	0.132	
				0.544	0.574	0.604	
	Blue	u _B v _B	Display: Blue Backlight: On	0.145	0.175	0.205	
				0.098	0.128	0.158	
% NTSC ratio	sRGB	(see 0)		-	130	-	%

Other optical parameters

	Symbol	Conditions	Specifications			Unit
			Min.	Typ	Max.	
Flicker			-	-	-25	dB

Definitions of Optical Parameters

a. Luminance

The luminance is measured at center point of the display with a white picture. The unit is cd/m².

b. Contrast

Contrast is measured by taking the ratio of the luminance of White and the luminance of Black. The contrast is measured over an area and not on single pixels.

$$CR = \frac{L_{WHITE}}{L_{BLACK}}$$

Transmissive measuring conditions: perpendicular to the glass, normal mode, illuminated with backlight system.

c. Viewing angle and viewing direction.

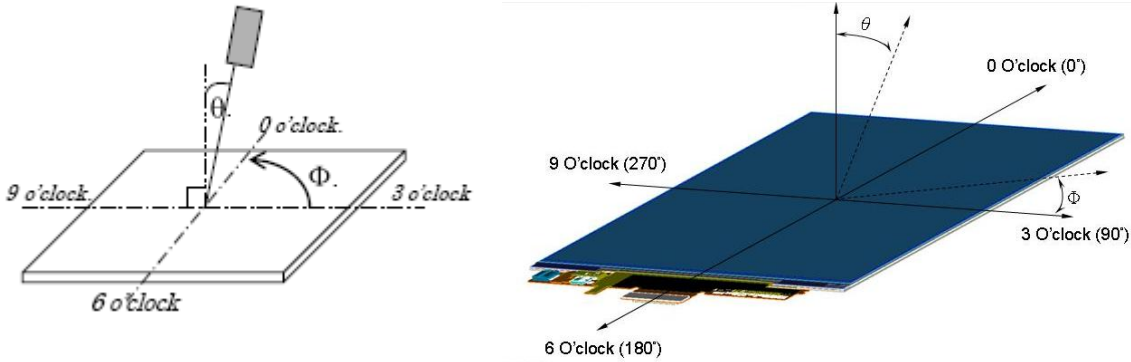

Definition of viewing angle and viewing direction

Optimal viewing direction is the viewing direction for which the display optical characteristics are optimized.

d. NTSC ratio

$$NTSC = \frac{\| \vec{RG}_{LCD} \times \vec{RB}_{LCD} \|}{\| \vec{RG}_{NTSC} \times \vec{RB}_{NTSC} \|}$$

\vec{RG} is the vector from Red u,v to Green u,v and \vec{RB} is the vector from Red u,v to Blue u,v. u and v are coordinates in the CIE1976 color system.

The NTSC-coordinates are set by:

Color	NTSC u'	NTSC v'
Red	0.499	0.522
Green	0.102	0.574
Blue	0.175	0.128

e. Polarization Transmission angle

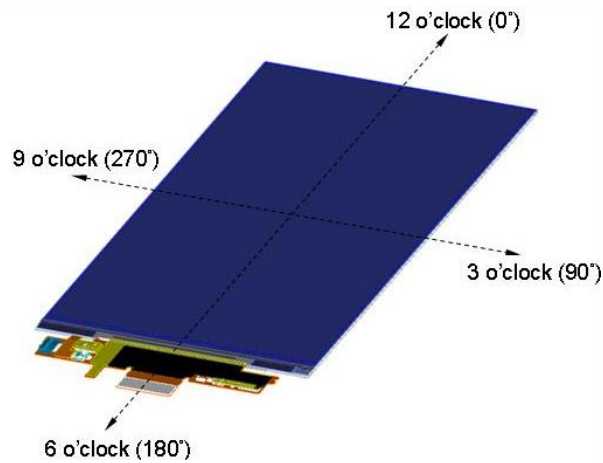

Polarization transmission angle

Polarization transmission angle is the transmission axis of the polarizer. Light coming from the display shall have a polarization direction that enables user to read the display with standard polarized sunglasses. The polarization orientation shall not be vertical & horizontal, the angle between polarizer & Vertical (or Horizontal) axis should equal or larger than 15°. Circular polarizer is preferred.

**E. Mechanism drawing:
[LCD Module]**

